

firesafe 2

A Science and Technology Syllabus Support Resource

for K-6 Teachers



FIREWISE



A free educational publication
by NSW Rural Fire Service

Introduction:

“Firesafe” offers a complete Science and Technology K-6 program for teachers. This program is derived from the Board of Studies (BOS) Syllabus. Headings for topics are basically the same as appear in the BOS document . Teacher learning programs can be developed from this program.

The central theme for this program is fire safety and awareness. The motive for this theme is to reduce the number of preventable fires that occur in our society and to reduce the number of injuries, deaths and damage that result from fires. Firesafe aims to complement the NSW RFS Fireguard for Kids Program which is already operating in many schools.

Teachers please note:

The activities in this workbook can be photocopied without permission provided that the NSW Rural Fire Service is acknowledged as the source.

Firesafe 1,2 & 3 are **FREE** publications of the NSW Rural Fire Service and are available in class sets.

Other resources

- K-6
Firesafe 1,2 & 3
- 7-12
Fire Science 1,2 & 3
- A comprehensive list of **FREE** resources is available on the NSW RFS web site: **www.rfs.nsw.gov.au**

For more information and enquiries call freecall 1800 654 443

CONTENTS

A look inside	3
Cycles in the world	6
How bush fires help gum trees	9
Bush fire in the Aussie bush	10
Eating out	12
Indoor Outdoor	15
Protecting forests and parks	17
Smokey's home	19
Keeping our houses safe from bush fire	21
Design a bush fire proof home.....	24
Keep in touch	25
Reporting fire and smoke	27
Making it easy	29
Material world	32
Fires change structures	34
Mini worlds	39
Bush fires and living things	40
Birds in the bush	41
Ants	43
My home the gum tree	44
Moving pictures	46
Our Australia	49
How aborigines used fire	52
Out and about	53
Modern fire tanker	56
Water bombing	57
Sounds great	59
What makes a bush fire roar.....	61
Sounds around us	62
Stuck on you	63

A LOOK INSIDE

A LOOK INSIDE

OUTCOMES	TEACHING STRATEGY	RESOURCES
<p>Recognise the systems of the human body.</p>	<p>1) Recognise that different parts of our body that undertake different roles:</p> <ul style="list-style-type: none"> • digestion of food • circulation of substances • removal of waste • transferring information <p>2) Examine a model of the human body and recognise the various organs.</p>	
<p>Distinguish the factors that contribute towards good health.</p>	<p>1) Discuss factors which contribute towards a healthy diet and healthy lifestyle.</p> <p>2) Survey eating habits.</p> <p>3) Compare healthy lifestyles and diet with unhealthy lifestyles and diet.</p> <p>4) Compare health/hygiene and diets of different cultures.</p> <p>5) Practise healthy habits (washing hands, cleaning teeth, not spitting).</p>	
<p>Undertake measurements of our body's physiological functions.</p>	<p>1) Measure lung capacity.</p> <p>2) Measure how long we can hold our breath.</p> <p>3) Measure our pulse rate.</p> <p>4) Measure body temperature.</p>	

Draw a line to
where the body organ belongs.

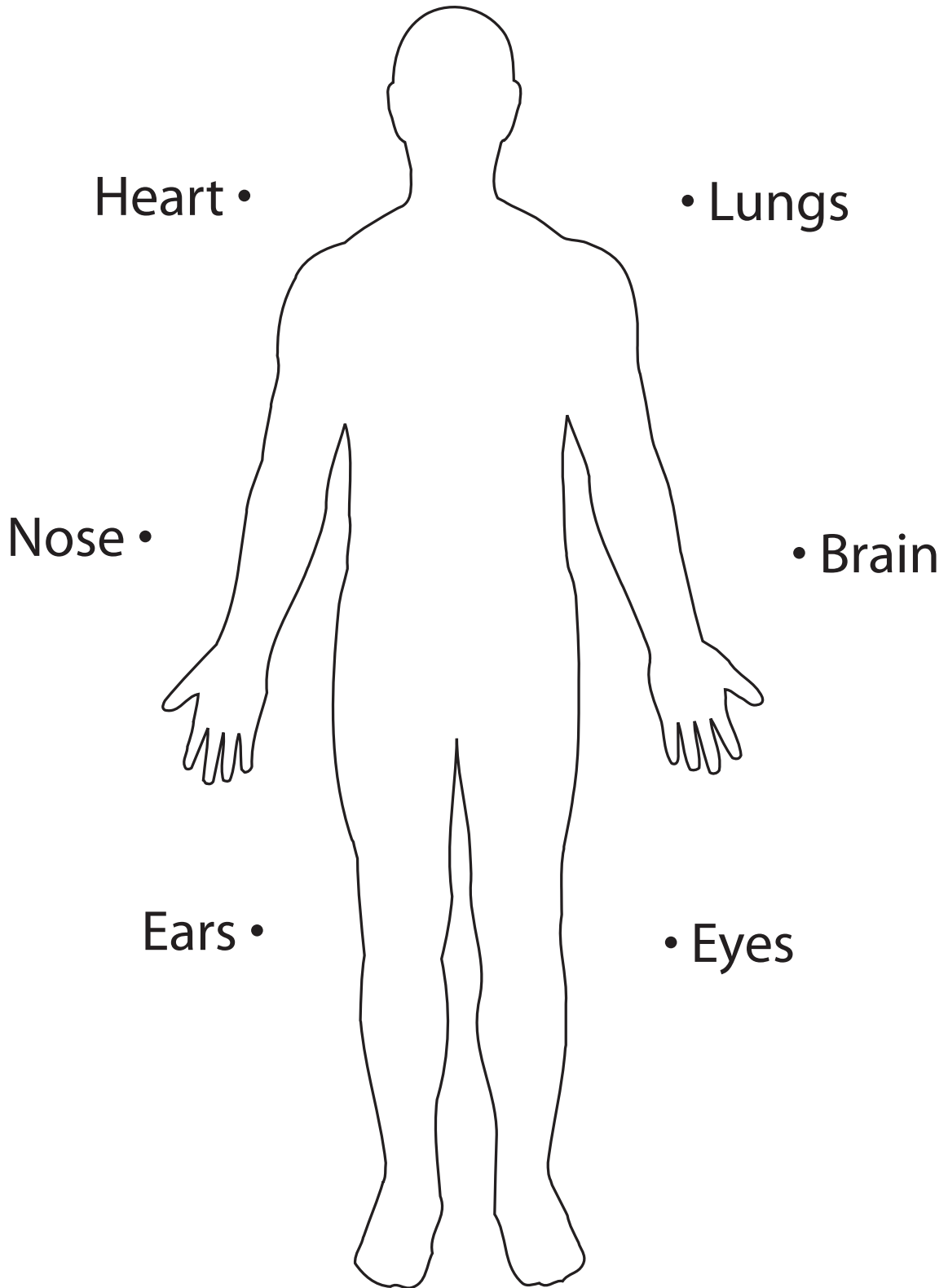

CYCLES IN THE WORLD

CYCLES IN THE WORLD

OUTCOMES	TEACHING STRATEGY	RESOURCES
<p>Recognise various cycles which exist in the living and non-living world.</p>	<ol style="list-style-type: none"> 1) Define what is meant by a cycle. 2) List a variety of living and non-living things which exhibit cycles. (water, gases, day, night, seasons, metamorphosis) 3) Record the cyclical change in temperature over several days. 4) Recognise the seasons and the times of the year when they occur. 5) Appreciate the differences in season which occur in different parts of the world. 6) Examine the interrelationships which exist between plants and animals in nature to facilitate the cycling of materials. 7) Construct simple food chains and food webs to demonstrate the cycle of energy in nature. 8) Recognise the role of bush fires in the life cycles of our native flora and fauna. (seed germination, adventitious roots and stems) 	

CYCLES IN THE WORLD

OUTCOMES	TEACHING STRATEGY	RESOURCES
<p>Design and use a method to record the life cycle of a living thing.</p>	<ol style="list-style-type: none"> 1) Recognise and produce the conditions needed for efficient seed germination. 2) Germinate some seeds and observe and record changes which occur over a period of time. 3) Design and produce an environment suitable for the growth of tadpoles. 4) Collect some tadpoles and observe and record changes which occur over a period of time. 5) Design and make an environment suitable for the metamorphosis of pupae into butterfly. 6) Collect butterfly pupae and observe metamorphoses. 7) Record height changes as our age changes from age 5 to 12. Devise a way to display this data. 8) Recognise the changing needs of plants and animals as they progress through their life cycle. 	
<p>Identify plant and animal products used to satisfy human needs.</p>	<ol style="list-style-type: none"> 1) List a variety of products which are derived from plants and animals. Prepare a poster or collage to demonstrate this. 2) Outline ways we can develop a recycling program at school and at home. 	

HOW BUSH FIRES HELP GUM TREES

Gum trees have flowers. The flowers attract bees which POLLINATE the flowers. Seeds develop from the flowers and are stored in a gum nut. When the weather is right the seeds are released from the gum nut. Bush fires are sometimes needed to allow the seeds to be released from the gum nuts.

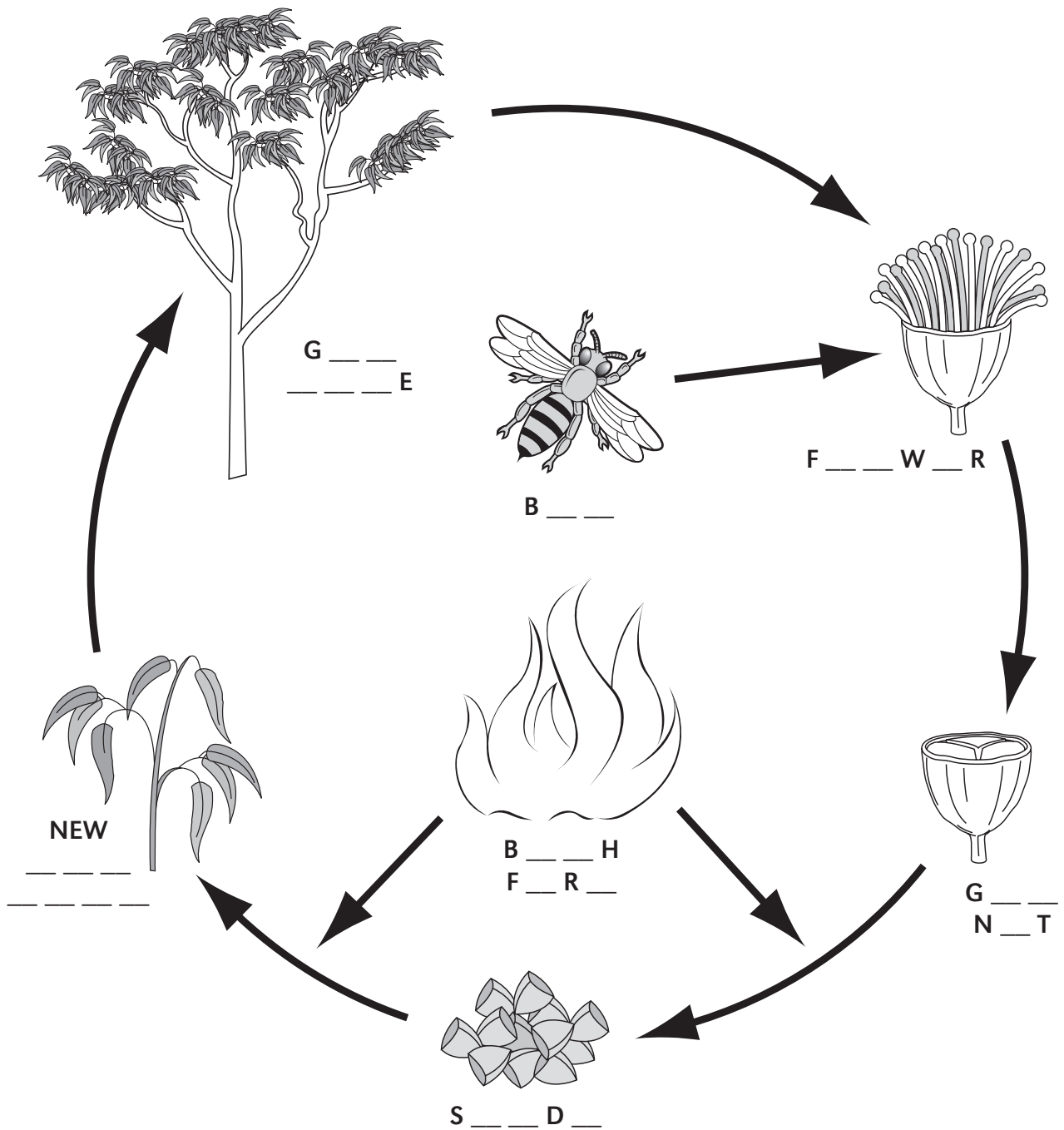

COLOUR IN THESE DIAGRAMS AND FILL IN THE MISSING LETTERS ON THE LABELS UNDER THE PICTURES

BUSH FIRES IN THE AUSSIE BUSH

- What usually happens in the Australian bush to make gum nuts release their seeds? _____

- What other things might help gum trees live after a bush fire?

- When you go through the bush how do you know that a fire has been there? _____

- Do the gum trees seem to suffer from a bush fire? _____
How do you know? _____

- Do lots of other plants survive a bush fire? _____
What sort? _____

- Do you think that bush fires are a natural part of the Australian bush? _____
How come? _____

- When do bush fires become a real problem? _____

Collect and draw some gum nuts.

**MATCH THE FOLLOWING WORD BEGINNINGS
WITH THE CORRECT WORD ENDINGS**

WORD BEGINNING	WORD ENDING
BUSH	VIVE
ENVIRON	ANTS
SUR	ALIAN
GUM	WERS
SUF	FER
PL	NATE
NAT	MENT
AUSTR	URAL
FLO	NUT
POLLI	FIRES

UNSCRAMBLE THESE WORDS

SCRAMBLED	UNSCRAMBLED
IEFR	
SBHU	
REET	
MUG	
EBES	
UNT	
PTNLA	

FINISH THESE SENTENCES BY ADDING A WORD FROM THE ABOVE LISTS.

1. The Australian bush has lots of _____ trees.
2. _____ fires happen every dry summer.
3. Lots of plants have flowers which need _____
to pollinate them.
4. Lots of Australian plants are able to _____ a bush fire.
5. Gum trees are able to store their seeds in a _____ nut.

EATING OUT

EATING OUT

OUTCOMES	TEACHING STRATEGY	RESOURCES
Analyse changes that occur during food preparation and cooking.	<ol style="list-style-type: none"> 1) Follow materials and ingredients from the raw state to the finished product. 2) Create a flow chart. 3) Prepare and cook a meal at school. 	
Determine the need for takeaway food and why we buy it.	<ol style="list-style-type: none"> 1) Organise a visit to a fast food restaurant for lunch. 2) Evaluate the meals in terms of nutritional value, value for money and convenience. 	
Appreciate the problems involved in preparing food for large numbers of people.	<ol style="list-style-type: none"> 1) Observe the methods of production while visiting a fast food restaurant. 2) Identify purposes and functions of machinery and utensils. 3) Compare methods of bulk food preparations in different cultures. 4) Discuss how large numbers of people can be catered for during an emergency such as a bush fire. 	
Design a healthy fast food service at school for a day.	<ol style="list-style-type: none"> 1) Model a fast food outlet for healthy foods at school. 	
Design a lunch for a specific purpose.	<ol style="list-style-type: none"> 1) Design a lunch for an active day in the bush. 2) Discuss the type of food that a firefighter should take with him or her when they are fighting a fire in the bush under hot conditions. 	

WHAT I EAT

	<i>Morning</i>	<i>Lunch</i>	<i>Dinner</i>
WEEK 1			
<i>Monday</i>			
<i>Tuesday</i>			
<i>Wednesday</i>			
<i>Thursday</i>			
<i>Friday</i>			
<i>Saturday</i>			
<i>Sunday</i>			
WEEK 2			
<i>Monday</i>			
<i>Tuesday</i>			
<i>Wednesday</i>			
<i>Thursday</i>			
<i>Friday</i>			
<i>Saturday</i>			
<i>Sunday</i>			

INDOOR OUTDOOR

INDOOR / OUTDOOR

OUTCOMES	TEACHING STRATEGY	RESOURCES
Identify how the community uses spaces and structures.	<ol style="list-style-type: none"> 1) Identify the major services which are used in the local community. 2) Identify structures which deliver services to the community (power lines, telephone lines, gas lines, fuels, water, sewage and garbage). 	
Identify useful materials which protect us from the environment.	<ol style="list-style-type: none"> 1) Collect and recognise a variety of building materials. 2) Identify those building materials which are fire resistant. 3) Recognise those components of the environment that we need to be protected from, in order to survive. 4) Compare the different types of buildings used by various communities to give protection from the environment. 	
Appreciate the need for having forests and parks.	<ol style="list-style-type: none"> 1) Describe the location of parks and forests in the local community. 2) List reasons for having parks and forests. 3) Recognise the impact of bush fires on parks and forests. 4) Develop responsible behaviour aimed towards protecting forests, parks and our community from bush fires. 	

PROTECTING FORESTS AND PARKS

If we go camping or have barbecues in an outdoor place such as a forest or park we must be very careful so that these places, and the places in which we live are protected from bush fires.

We must always use a fireplace which has been made properly. Most parks and forests have fireplaces already made and we must use them.

Things which are likely to catch fire should not be any closer than 2 metres. Make sure there are no logs or stumps closer than 3 metres.

An adult should always be present and the fire should not be left to burn unattended. Make sure the fire is put out before you go home.

You are not allowed to light any fires during a total fire ban.

1. How many of your steps measure 2 metres and 3 metres?

2 metres = _____ steps 3 metres = _____ steps.

2. On what type of day is it good to go camping? _____

3. What nasty things can also happen on this type of day? _____

3. Make a list of the things you take camping which could burn if they are placed too close to the campfire. _____

(Closer than _____ steps)

4. If you went camping and there were no fireplaces, how would the adult you are with, make a safe campfire? _____

5. How could the fire be put out before you go home? _____

6. How could the fire spread from the campfire to a log or stump?

F	I	R	E	P	L	A	C	E	P
O	E	U	C	E	B	R	A	B	A
R	R	E	C	S	S	E	M	A	R
E	P	N	A	P	R	G	P	D	K
S	M	R	M	O	O	N	S	U	S
T	E	U	P	B	O	A	I	L	G
S	T	B	I	U	D	D	T	T	O
S	R	G	N	I	T	A	E	H	L
N	E	S	G	L	U	I	B	L	E
H	S	U	B	D	O	F	I	R	E

FIND THESE HIDDEN WORDS.

ADULT BARBECUE BURN BUSH CAMPING
CAMPSITE DANGER FIRE FIREPLACE FORESTS
HEATING LOGS METRES BUILD OUTDOOR
PARKS STUMPS

THE LETTERS WHICH ARE LEFT OVER SPELL OUT A WORD
WHICH DESCRIBES HOW WE SHOULD BE AT CAMPFIRES

SMOKEY'S HOME

Complete the following dot to dot to find out who SMOKEY is, then read or have someone read to you "SMOKEY'S HOME"

JOIN 1 TO 18, LIFT YOUR PENCIL THEN JOIN 19 TO 49

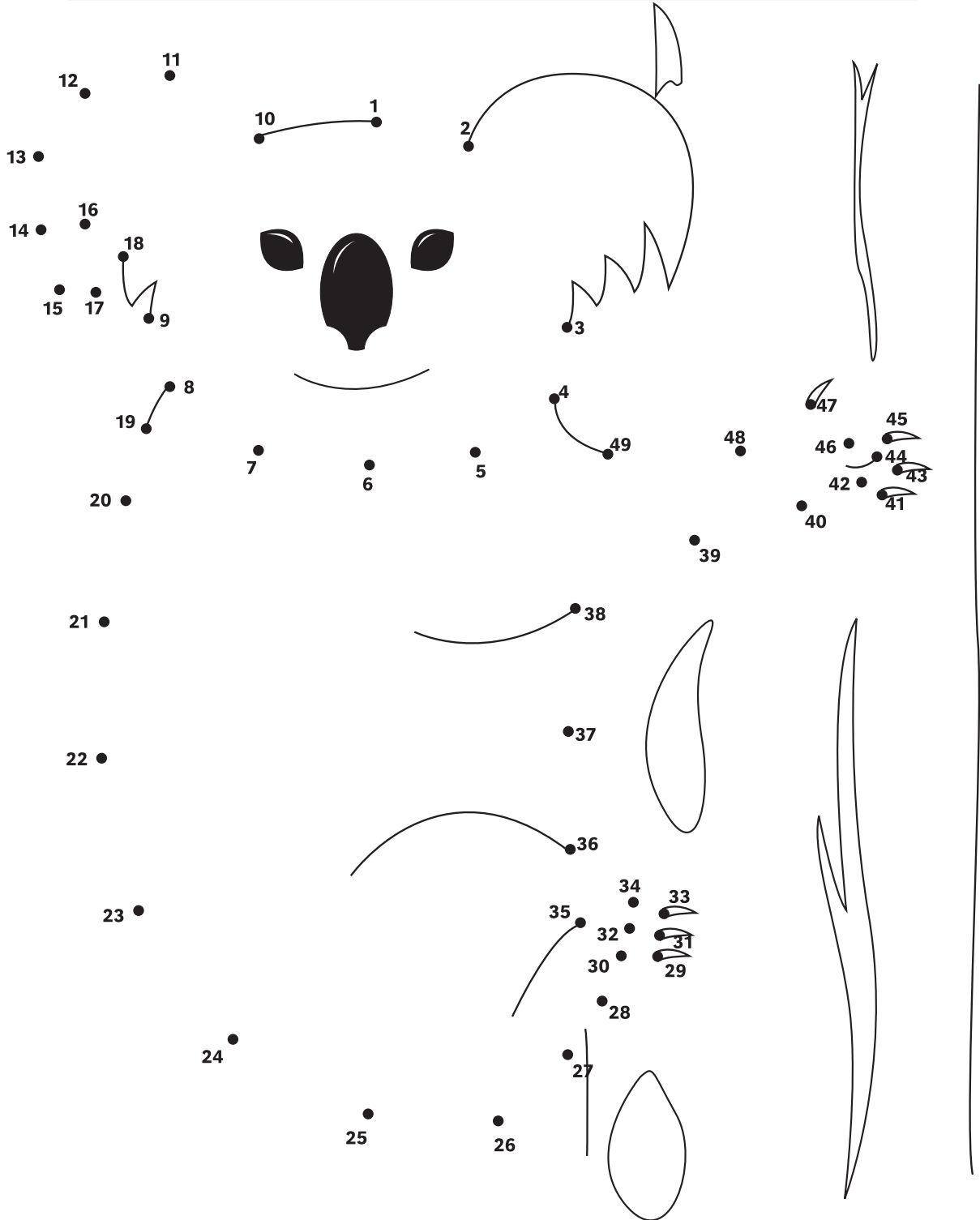

COLOUR ME IN

Answer these questions about:

SMOKEY'S HOME

1. What was Smokey worried about?

- what he was going to have for tea OR
- bush fires and how they burn trees OR
- leaving a mess behind him

☒ _____

2. Smokey's home was?

- in a gum tree OR
- in a hole down by the creek OR
- in a hollow branch in a dead tree

☒ _____

3. What did Sid the Emu tell Smokey to do?

- learn how to run real fast OR
- call the Bush Fire Brigade OR
- chop off all of the branches

☒ _____

4. What did Floss the Frog tell Smokey to do?

- move his tree to a safer place OR
- learn to eat grass OR
- live in the swamp

☒ _____

5. What did Smokey's dad tell Smokey to do?

- don't be a silly Koala OR
- do the washing up OR
- clean up all of the leaves and sticks around his tree

☒ _____

KEEPING OUR HOUSES SAFE FROM BUSH FIRES

If we live in the bush we have to make our houses safe from bush fires.

A WELL PREPARED HOUSE PROTECTS US FROM BUSH FIRES

Look at these two pictures showing a house which is safe from bush fires and one which is not safe from fire. Place a big tick on top of the safe house. Circle the changes that should be made to the house that is not safe and write what needs to be done to fix the problem.



These are some things that should and should not be done to make our houses safe. Place a tick in the column to say if it is a safe thing or a thing that is unsafe.

THINGS WE DO	SAFE	NOT SAFE
1. Grass is cut and kept green.		
2. Trees are too close to the house.		
3. Screens on the windows.		
4. Rubbish on the verandah.		
5. Garden to act as fire break.		
6. Rubbish in the yard.		
7. Clean and clear under the house.		
8. Holes in the roof.		
9. Leaves in the gutters.		
10. Petrol stored near the house.		

Place numbers onto the diagrams of the houses that are the same numbers as the safe and not safe things in the list.



Match the following word beginnings with the word endings.

WORD BEGINNING	WORD ENDING	WHOLE WORD
HO	DEN	
SCR	NDAH	
WIN	PARE	
RUB	USE	
VERA	VES	
GAR	OF	
RO	DOWS	
LEA	FIRES	
GUT	ASS	
PET	BISH	
PRE	TER	
BUSH	EENS	
GR	ROL	

Some of these words can be used to finish these sentences:

If you live in an area where there are many bush _ _ _ _ _ you must make your home _ _ _ _ _.

Clear all _ _ bb _ _ _ from around the house.

Get all of the _ _ _ves out of the _ _ _ _ _ _ _ _ _.

Keep the _r_ _s short and green.

No p_ _ _ _ _ or other fuels should be stored near the house.

The _ _ _ _ _ws should have metal sc_ _ _ _ _ on them to stop sparks.

DESIGN A BUSH FIRE PROOF HOME

1. On a large piece of paper, say A3 size, design and draw a house that could survive a bush fire.
2. With arrows, label the features on the house that would enable it to survive.
3. Talk with your teacher or watch a video about why houses burn down in bush fires (ember attack).
4. Colour in your diagram.
5. Make a short presentation to your teacher or class. Describe the safety features of the house.
6. Your diagram should show the direction that the house faces (the aspect).
7. Your house can be located in an town or country setting.

KEEP IN TOUCH

KEEP IN TOUCH

OUTCOMES	TEACHING STRATEGY	RESOURCES
Use a telephone to effectively communicate information.	<ol style="list-style-type: none"> 1) Observe and practise correct telephone technique. 2) Know how to report a fire or other information over the telephone. 3) Use the telephone to obtain information (weather, time). 	
Investigate a variety of ways used to communicate a message.	<ol style="list-style-type: none"> 1) List a variety of ways in which messages can be transferred between people. 2) Compare and contrast various methods of communication. 3) Practise effective letter writing. 	
Design and construct a method to communicate a message across the playground or from one building to another.	<ol style="list-style-type: none"> 1) Construct a string telephone. 2) Develop a system of hand signals to convey a message. 3) Discuss situations where hand signals could be used. 4) Develop a code to use with flashing lights (morse code). 	

REPORTING FIRE AND SMOKE

If there is a fire in your house or you see smoke or fire in another house you must follow these steps.

- 📞 1. Get out of the burning house immediately.
- 📞 2. Go to the nearest telephone or tell an adult.
- 📞 3. Call the emergency number 000.
- 📞 4. 000 will ask what service you want (Ambulance, Police or Fire).
Say who you are , where you live and where the fire is. Speak slowly and clearly. **REMAIN CALM.**
- 📞 5. Answer all questions calmly and clearly.
- 📞 6. Do not hang up until you are told.
- 📞 7. Wait for the Fire Brigade to arrive and tell them where the fire is.

000 000 000 000 000



Report fires



RING

0 0 0

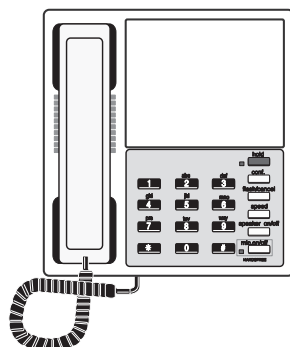

Ring 000

Give:

- ✓ Your name
- ✓ Your Address
- ✓ Where the fire is
- ✓ Stay calm
- ✓ Speak Clearly

DRAW ARROWS BETWEEN THE FOLLOWING BOXES TO SHOW THE STEPS TO FOLLOW IF THERE IS A FIRE.

Use these words to fill in the spaces in the boxes (some words may be used more than once):

you

immediately

telephone

brigade

slowly

where

doors

000

panic

leave

burning

Tell the emergency number
who _____ are, _____
you live, the number you
are ringing from, where the
_____ is and what is
_____ and answer any of
the questions you are asked.

If your house is on fire
you must _____ the house
_____. Shut any
_____ behind you.

If there are no adults
find the closest

and call _____.

Dial ____ and ask for
_____. Speak
clearly and _____,
dont _____.

When the fire _____
arrives, tell them where
the fire is.

MAKING IT EASY

MAKING IT EASY

OUTCOMES	TEACHING STRATEGY	RESOURCES
Investigate how simple machines make work easier.	<p>1) List a variety of gadgets which we use in everyday life to make simple tasks easier eg. (broom, bottle opener, can opener, axe, wheels, wheelbarrow, golf clubs)</p> <p>2) Categorise simple machines as being levers, ramps and wheels.</p>	
Investigate how simple tasks have changed with the development of technology.	<p>1) Create a museum display to show old and new gadgets:</p> <ul style="list-style-type: none"> • writing devices • egg beaters • brooms • clocks • can openers • bottle openers • axes • golf clubs • hammers <p>2) Compare the efficiency of materials used in the manufacture of gadgets.</p> <p>3) Invite a senior citizen to the school to explain how they used gadgets to undertake everyday tasks.</p>	
Investigate the use of simple machines in traditional Aboriginal culture.	<p>1) Explore the various types of tools used in Aboriginal culture.</p> <p>2) Invite a guest speaker to demonstrate their use.</p> <p>3) Compare the use of tools and gadgets in traditional cultures.</p>	

Draw a line to identify the machine that makes their task easy



Put out fire

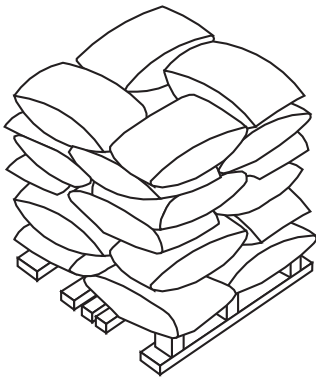
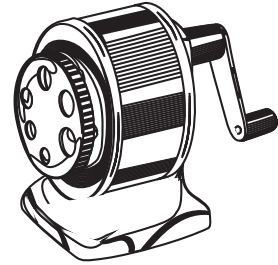

Lift heavy load

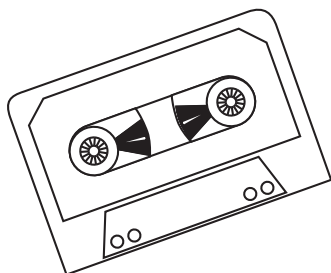

To play tape

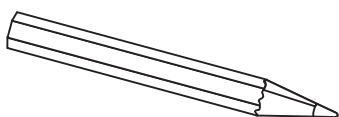
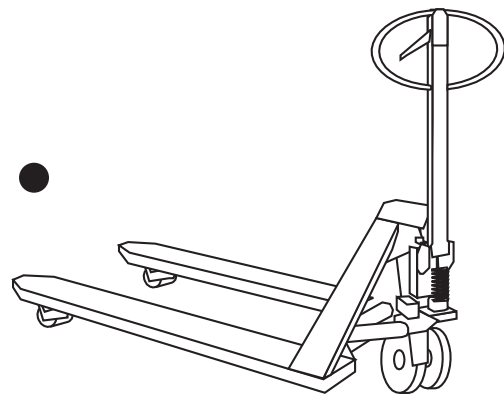

Sharpen pencil

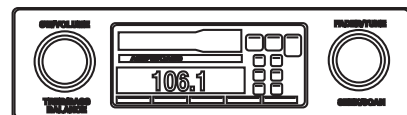

MATERIAL WORLD

MATERIAL WORLD

OUTCOMES	TEACHING STRATEGY	RESOURCES
<p>Identify materials as being solids, liquids and gases.</p>	<ol style="list-style-type: none"> 1) List objects around us that can be grouped as being solids, liquids and gases. 2) Make chocolate shapes using a mould. 3) Make candles. 4) Recognise that heat changes the state of matter. 	
<p>Identify the wide range of materials used in construction.</p>	<ol style="list-style-type: none"> 1) Examine a variety of structures in the local environment and record the materials from which they are made. 2) Recognise shapes that add strength to structures. 3) Categorise materials that are recyclable or renewable. 4) Design and make a structure or device to perform a given task (support a weight, transport a material, protect something, keep something dry) 	
<p>Investigate how forces in the environment can change materials and structures.</p>	<ol style="list-style-type: none"> 1) Examine factors that make things rust. 2) Examine the affect of fires on structures. 	

FIRES CHANGE STRUCTURES

Heat and flames from a fire cause objects to change.
Some of these changes are:

1. Fire makes objects simpler.

An example of this would be changing wood or paper into ash.

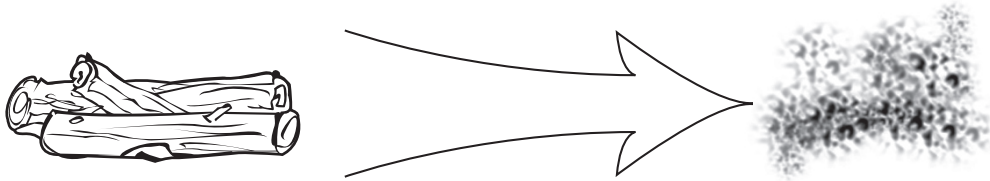

- Draw the burning wood in the diagram.

2. Fire makes things melt or evaporate.

Lots of furniture in our houses melts before a room actually bursts into flames. Some things that would do this are clocks, picture frames, telephones, television, chairs and carpets.

- Make a list of things in this room which you think might melt .



These things would melt in a room:

_____	_____	_____
_____	_____	_____
_____	_____	_____

Spray cans are very dangerous when they burn because the liquids inside of the spray can change into a gas which can make the can burst .

NEVER DISPOSE OF SPRAY CANS BY BURNING THEM

How should people can get rid of spray cans?

What sorts of things are in spray cans in your house? _____

3. Fire Makes Gases.

Many plastics make gases which are poisonous when they are breathed. Lots of things used to make car parts do this. If you see a car burning , stay well away.

What other things might be dangerous when a car is burning?



4. Fire makes things get bigger.

Train tracks get bigger and buckle when they are heated. They might even do this on a very hot day.

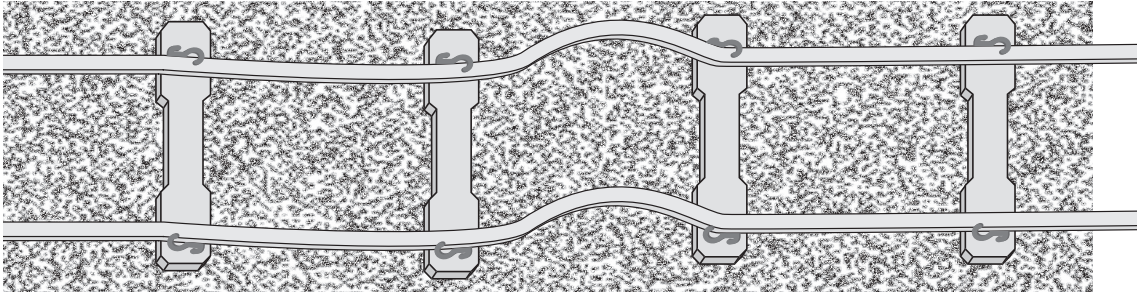

How can you undo a tight lid off a jar? _____

What must you be careful of if you are doing this? _____

Power lines sag on hot days. What would happen if a fire was burning under or near power lines? _____

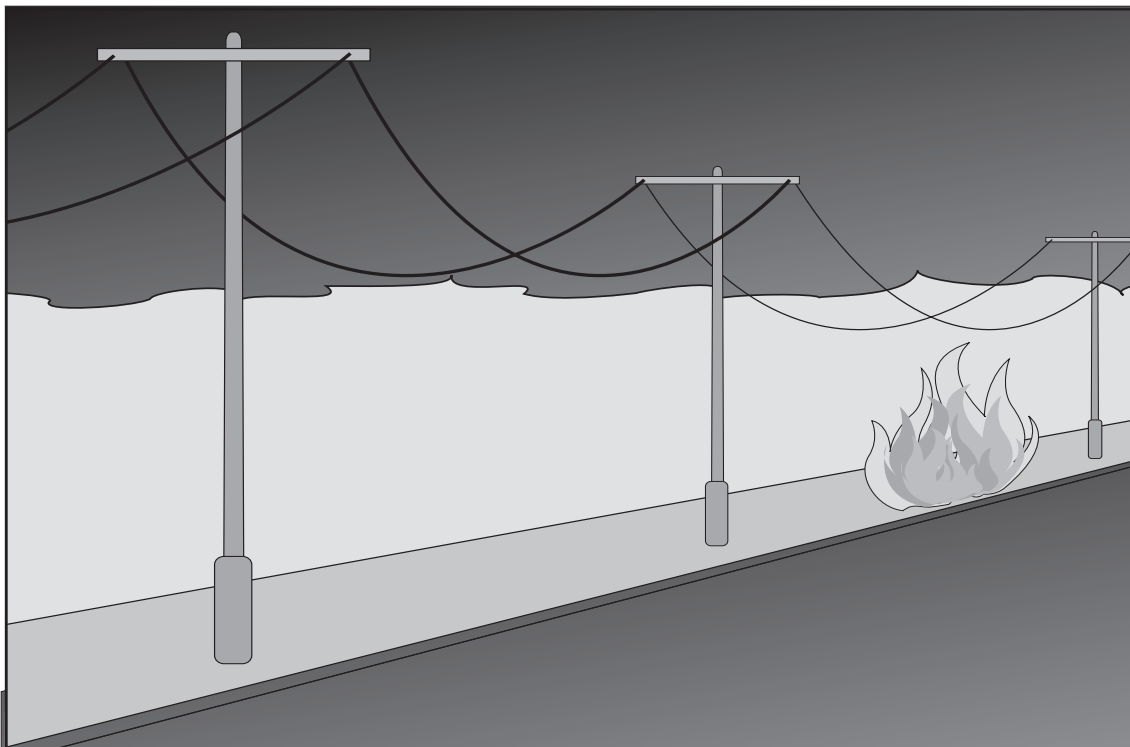

5. Fire is sometimes used to make some metals harder.

The heat however makes them brittle. This means that if they were hit they would break.

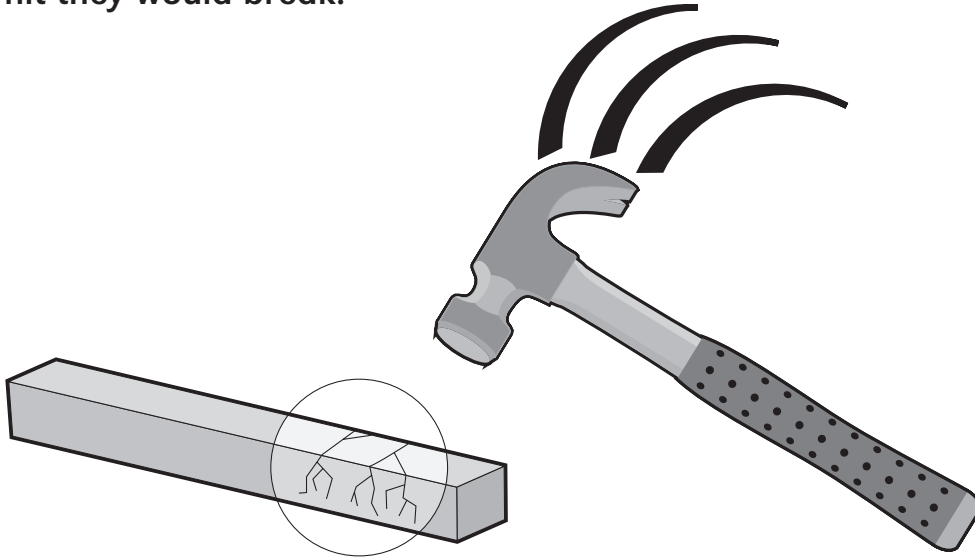

6. Fire is sometimes used to make metals softer.

We do this so that the metals can be hit into shape.

Horse shoes are made in this way.

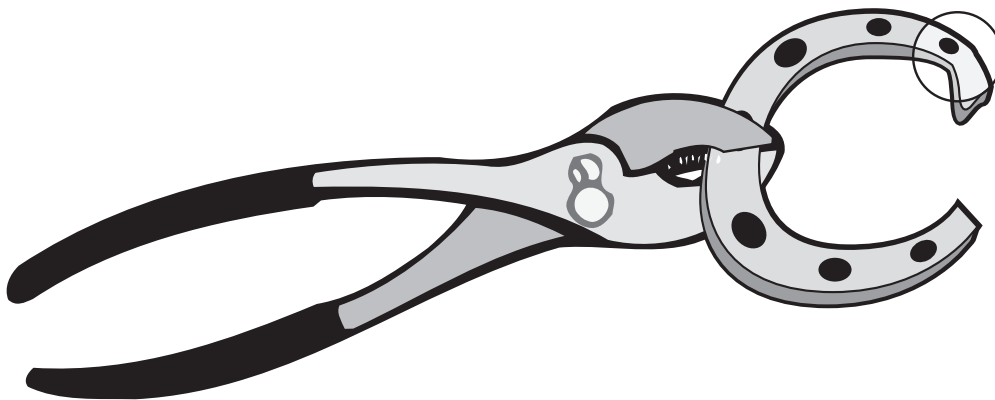

MINI WORLDS

MINI WORLDS

OUTCOMES	TEACHING STRATEGY	RESOURCES
Discover the interrelationships which exist between living things and the environment.	<ol style="list-style-type: none"> 1) List the factors which all living things need to survive. 2) Observe and describe the behaviour of animals as they interact with the environment. 3) Recognise the existence of mini environments within the school grounds and at home. 	
Examine factors which affect the distribution of living things in the environment.	<ol style="list-style-type: none"> 1) Measure variations of light, temperature, availability of water and shelter in a mini environment. 	
Appreciate the balance living things have in their environment and how bush fires affect this balance.	<ol style="list-style-type: none"> 1) Examine the effects bush fires have on the environment 	
Undertake activities which are beneficial to the environment.	<ol style="list-style-type: none"> 1) Design and modify an area of the playground to attract new types of animals, eg. birds. 2) Undertake a tree planting program in association with a local Landcare group. 	
Develop a database to record the existence of the variety of living things in the environment.	<ol style="list-style-type: none"> 1) Record the types of living things existing the environment. 2) Discuss ways to record the abundance and distribution of living things. 	
Investigate behaviour.	<ol style="list-style-type: none"> 1) Investigate interrelationships which exist in the environment. 2) Categorise behaviour as feeding, breeding, seeking shelter or protection. 3) Construct simple food chains and food webs. 	

BUSH FIRES AND LIVING THINGS

TALK ABOUT AND WRITE THE ANSWERS TO THESE QUESTIONS.

BEFORE THE BUSH FIRE:

1. What sorts of things will the animals eat? _____

2. Where do the animals hide? _____

3. Where do the animals have their babies? _____

4. Where do the animals go to get out of bad weather? _____

5. Where do the animals go to sleep? _____

DURING A BUSH FIRE:

1. What things will hurt or kill animals? _____

2. How can animals get away from the fire? _____

3. Which animals are most likely to survive? _____

4. Which animals are likely to get burnt? _____

5. Where will animals go during a fire? _____
If they run away? _____
If they stay around? _____

AFTER THE BUSH FIRE

1. What will the animals eat? _____

2. Where will they live? _____

BIRDS IN THE BUSH

In the place where you live, you can always find birds sharing your outdoor space. Some of the birds which live near my place or around the school are:

Colour in these pictures of some common bush birds.

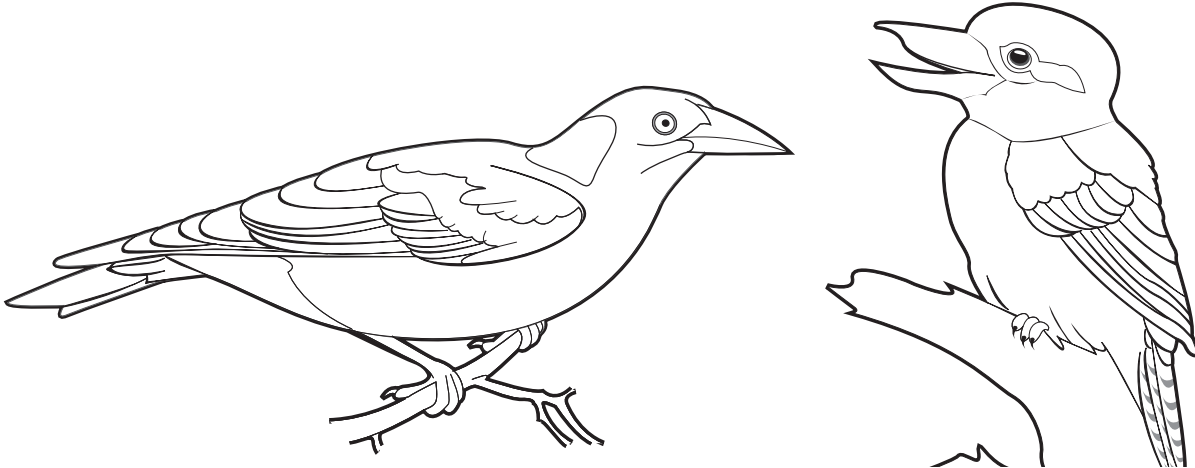

You can attract birds by making a bird table.

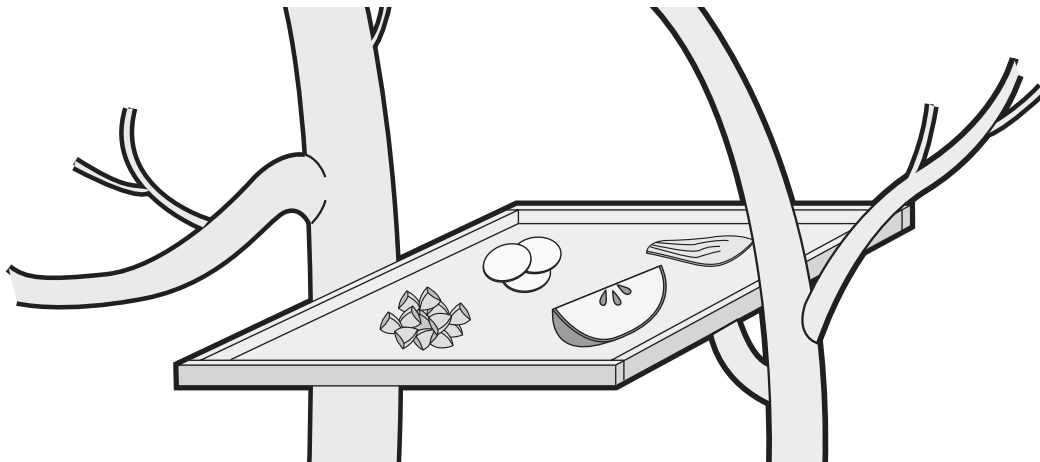

Watch the birds that visit it.

Fix your table onto a spot so that the birds are not frightened (it shouldn't move). Place a variety of foods onto the table and record the types of food eaten by different birds. Record your results in the following table. Talk about what you think the bird might eat in the bush and write this into the last column in your table.

DATE	KIND OF BIRD	WHAT IT LIKES TO EAT	WHAT IT MIGHT EAT IN THE BUSH

If a bush fire happens in the place where these birds live, what would happen to them? _____

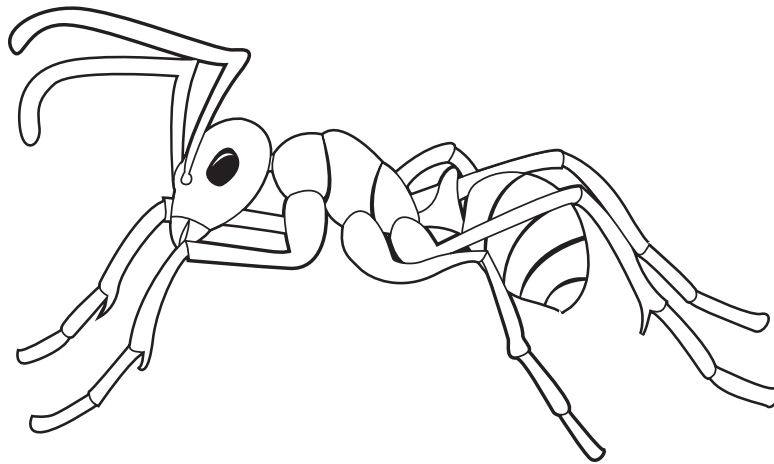

Ants are animals that are very good at surviving bush fires. Some of the places where we find lots of different types of ants are:

Many ants live deep in the ground in tunnels. This protects the ants from bush fires. If there are lots of ants living in an area it means that the environment is very healthy. We can use ants to tell us how the environment gets better after a bush fire.



Name some other animals that might live in burrows or holes in the ground. (They would also be protected from bush fires).

MY HOME THE GUM TREE



Here is a list of animals that might call the old gum tree home:

cockroach	lizard	termite	aphid
ant	parrot	owl	bat
spider	magpie	goanna	possum
koala	frog	kookaburra	

These animals are hidden in the following word puzzle. Find them and write out the hidden fire message.

S	P	I	D	E	R	T	I	H	D
O	N	T	L	T	L	N	C	I	K
E	A	P	H	I	D	A	T	A	B
B	U	S	Z	M	O	W	L	N	H
F	P	A	R	R	O	T	I	N	R
E	R	S	K	E	I	P	G	A	M
D	A	C	R	T	A	L	A	O	K
P	O	S	S	U	M	O	U	G	N
C	R	A	T	D	Y	H	O	M	E
K	O	O	K	A	B	U	R	R	A

cockroach

lizard

termite

aphid

ant

parrot

owl

bat

spider

magpie

goanna

possum

koala

rat

kookaburra

What is the hidden message:

___ / ___ ___ / ___ ___ ___ / B ___ ___ ___ / ___ I ___ ___ ___

___ R ___ ___ ___ ___ / M ___ / ___ ___ M ___

MOVING PICTURES

MOVING PICTURES

OUTCOMES	TEACHING STRATEGY	RESOURCES
Investigate how pictures appear to move.	<ol style="list-style-type: none"> 1) Create a “flip book” to create a perception of movement. 2) Examine a series of optical illusions. 3) Advance a video one frame at a time to observe how movement is created. 	
Analyse techniques used to create different pictures.	<ol style="list-style-type: none"> 1) Take trick photos to create an illusion. 2) Use the computer to alter photos. 3) Collect a variety of pictures from magazines to demonstrate different techniques. 4) Examine the effect of a “blue screen”. 	
Investigate animation using film, video and computer technologies.	<ol style="list-style-type: none"> 1) Use a series of pictures or photos to create and write a simple story. 2) Discuss favourite TV ads and the factors which make them good. 	
Design and make an animated program.		

WRITE IN BOXES BELOW IN ORDER OF SEQUENCES TO CREATE A MOVING SCENE

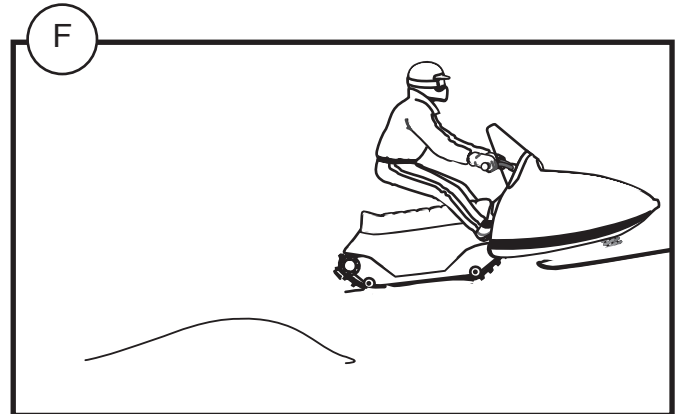
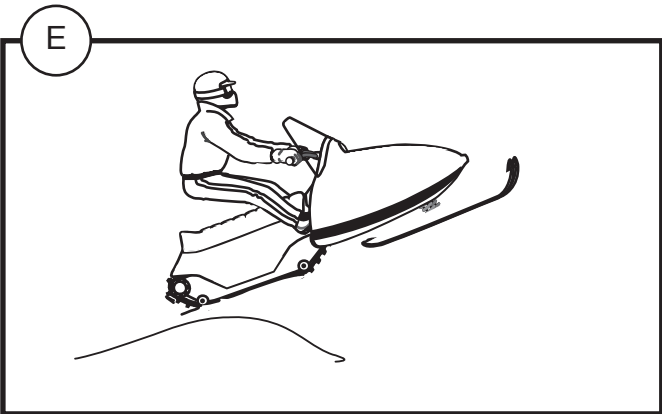
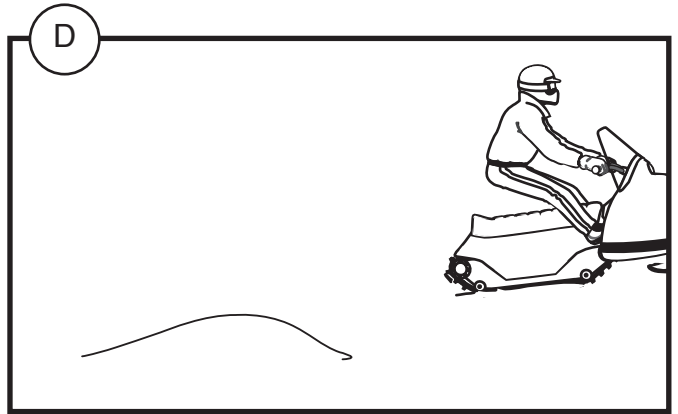
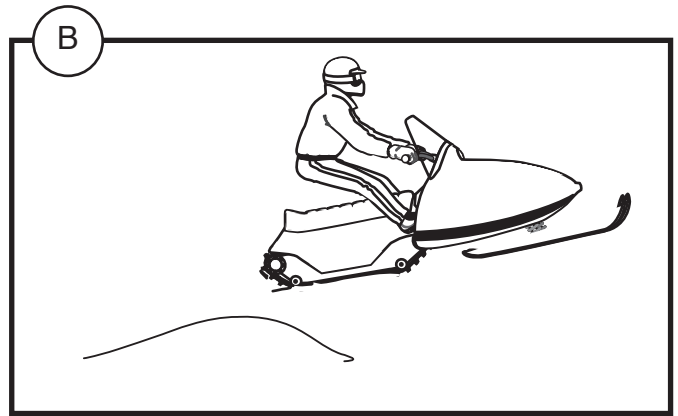
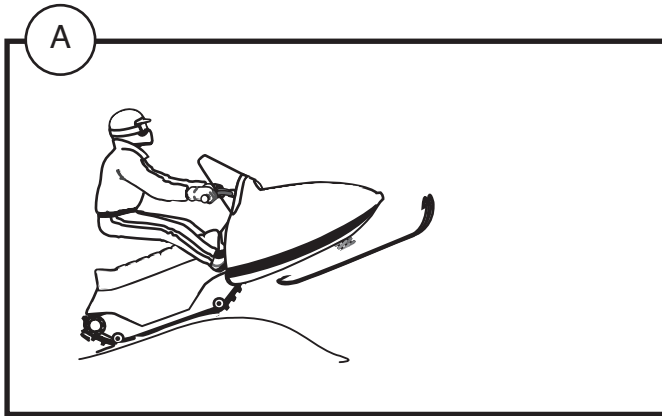

--	--	--	--	--	--	--

OUR AUSTRALIA

OUR AUSTRALIA

OUTCOMES	TEACHING STRATEGY	RESOURCES
<p>Identify the variety of plants in the environment.</p>	<ol style="list-style-type: none"> 1) Examine the leaves of a variety of plants in the school environment. 2) Group leaves and plants according to the shape of their leaves. 3) Construct a simple key to identify plants. 4) Recognise the main groups of plants (algae, mosses, ferns, pine trees, flowering plants). 5) Identify plants and other resources used in traditional Aboriginal culture for food, medicines, tools, shelter and weapons. 6) Discuss the traditional role of fire in the Australian environment. 	
<p>Identify the variety of animals which exist in the environment.</p>	<ol style="list-style-type: none"> 1) Recognise the differences between vertebrate and invertebrate animals. 2) Collect a variety of insects and record differences. 3) Use a simple key to identify invertebrates. 4) Recognise the various groups of vertebrate animals. Recognise our place in the animal world. 5) Collect pictures of a variety of animals and display this information as a poster or collage. 6) Construct an animal museum. 7) Examine a variety of preserved animals. 8) Construct a database to develop a profile of some selected animals. 	

OUR AUSTRALIA

OUTCOMES	TEACHING STRATEGY	RESOURCES
<p>Investigate specific Australian environments.</p>	<ol style="list-style-type: none"> 1) Name various ecosystems which exist in the Australian environment (rainforest, seashore, desert, grassland, eucalypt forest). 2) Identify specific environment types in the local area. 3) Undertake a visit to a special environment type which exists in the local area. 4) Understand how the Australian environment is adapted to bush fires. 5) Identify the types of environments. 	

HOW ABORIGINALS USED FIRE

Aboriginals used fire as a tool to help them go about their daily lives. They lit fires to keep the ridges clear of grass so that it was easier to travel. Fires caused new grass to grow that attracted kangaroos and wallabies that could be hunted. Fires also made it easier to hunt smaller animals.

Aboriginals often took fire with them when they travelled by carrying burning or smouldering pieces of wood or bark. These were called firesticks. Fires were also used for sending signals, ceremonies, cooking and to keep them warm.

1. Why did Aboriginals keep the ridges clear of grass? _____

2. What was attracted to the new green grass that grew after the fire ?

3. What were the smouldering sticks used to start fires called?

4. List two other ways that aboriginals used fire? _____

5. Complete the following words. Each word has been used in the passage.

kangar_____	_____iginals,	wall_____
_____vel,	_____mals,	rid_____
_____sticks,	hun____,	smoul_____
_____king.		

OUT AND ABOUT

OUT AND ABOUT

OUTCOMES	TEACHING STRATEGY	RESOURCES
Investigate the transport systems used by students.	<ol style="list-style-type: none"> 1) Survey students to determine the most common way that they arrive at school. 2) Compare the efficiency of various means of transport. 3) Discuss alternative ways that we could arrive at school and compare the advantages and disadvantages of each means of transport. 	
Develop an understanding of the need to develop bicycle safety.	<ol style="list-style-type: none"> 1) Recognise the working parts of a bicycle. 2) Design a set of safety rules aimed towards developing a sense of bike safety. 3) Examine the structure of a bicycle helmet. 	
Investigate how transport needs have been met in the past.	<ol style="list-style-type: none"> 1) Visit a museum to examine old forms of transport. 2) Discuss how our parents and grandparents used to get to school. 3) Collect pictures of old fire trucks. 4) Compare changes in lifestyle which have resulted from changed transport systems. 5) Discuss how modern transport systems change the way in which bush fires can be put out (water bombing, modern fast vehicles). 	

OUT AND ABOUT

OUTCOMES	TEACHING STRATEGY	RESOURCES
<p>Recognise the importance of having safety rules associated with transport systems.</p>	<ol style="list-style-type: none"> 1) Discuss some of the road rules which have to be observed when adults drive their cars. 2) Develop a set of safety rules which should be observed when children travel in cars and other vehicles. 3) Recognise the importance of wearing seat belts and bicycle helmets. 4) Develop and practise safety rules associated with riding bicycles. 5) Develop a set of safety rules designed to stop people getting hurt with inline skates, skateboards and scooters. 6) Recognise problems which exist in towns with the use of inline skates, skateboards and scooters. 7) Recognise designated areas for using such equipment. 	
<p>Recognise the things that make vehicles move.</p>	<ol style="list-style-type: none"> 1) Categorise vehicles according to the energy sources they use. 2) Recognise the components of vehicles which make them move. 	
<p>Design and construct a model of a futuristic transport system.</p>	<ol style="list-style-type: none"> 1) Use lego or plasticine to construct a futuristic means of transport. 2) Write a simple report outlining the transport system. 	
<p>Design solutions to student transport systems.</p>	<ol style="list-style-type: none"> 1) Recognise problems associated with various transport systems. 2) Design a transport system that aims to solve many of these problems. 	

MODERN FIRE TANKER

Colour in the picture of the modern fire tanker.

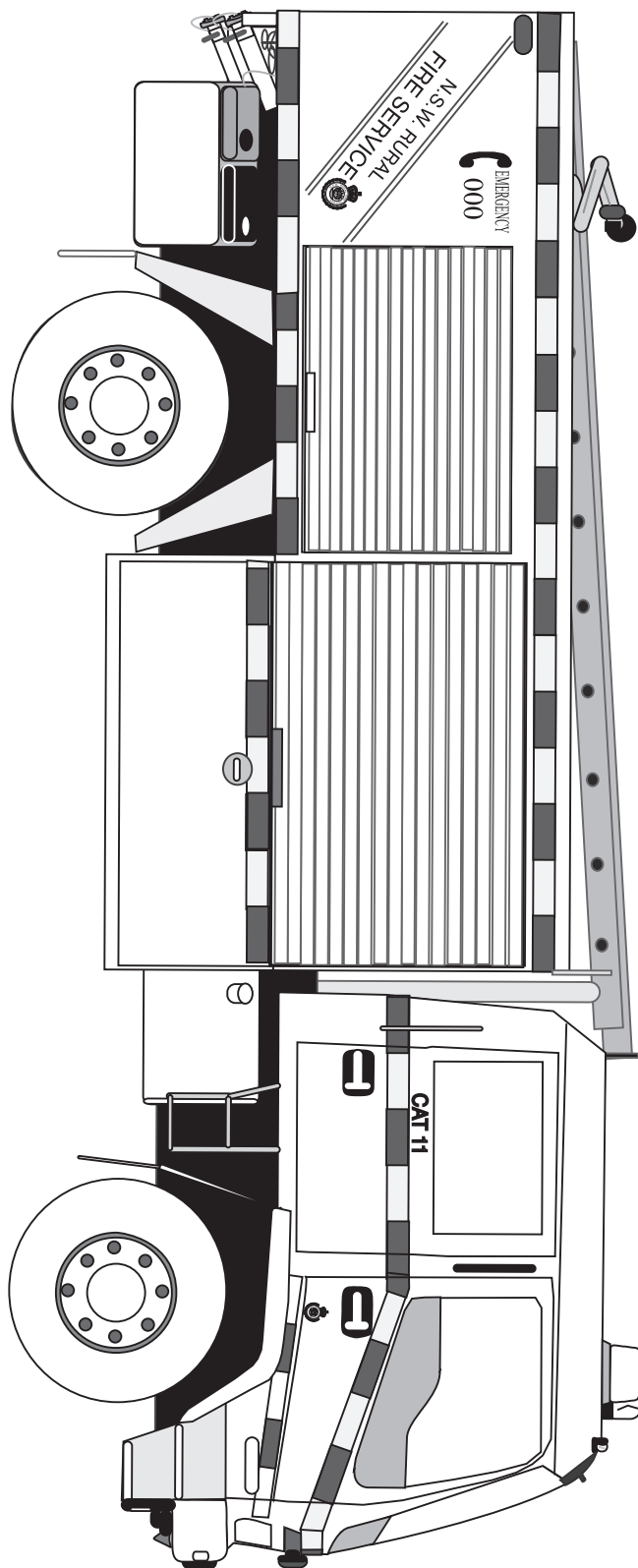

WATER BOMBING

Colour in the following diagram of a plane which is used to “bomb” water onto a bush fire.

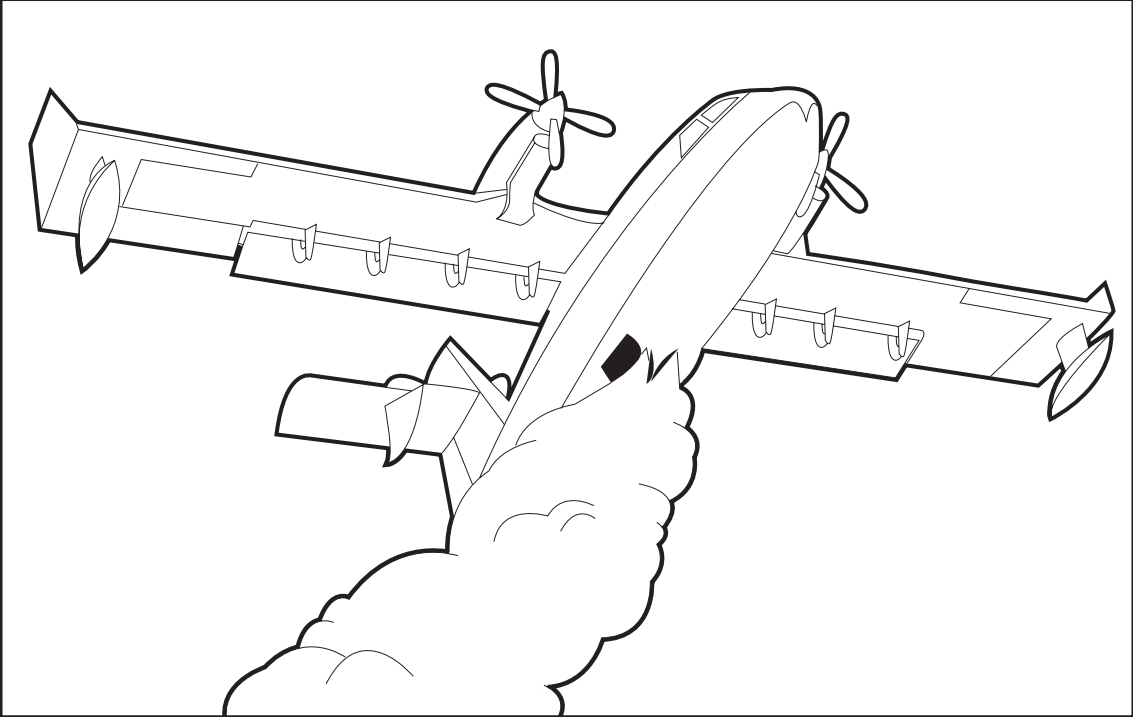

Here is a picture of a fire tanker which was used in 1956.

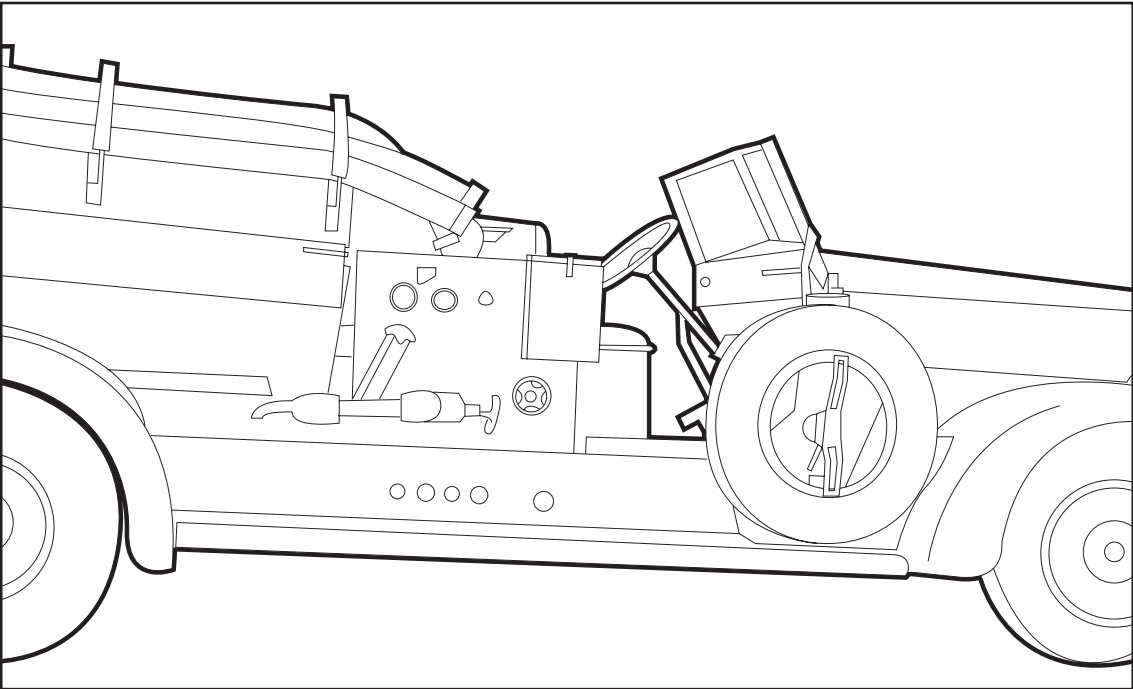

Talk about and write down some things which would be different about fighting fires with the old tanker and fighting fires with the new tanker.

Talk about and write down some things that would be different about using planes and helicopters to fight fires (water bombing).

SOUNDS GREAT

SOUNDS GREAT

OUTCOMES	TEACHING STRATEGY	RESOURCES
Investigate the origins of sound.	<ol style="list-style-type: none"> 1) List a variety of ways in which sound can be produced. 2) Deduce that sound is caused by vibrations. 3) Observe a variety of musical instruments and describe the sounds produced by each of them. 4) Construct a “bush band” instrument. 	
Investigate the transmission of sound.	<ol style="list-style-type: none"> 1) Compare the transmission of sound through air and water. 2) Deduce that sound needs something to travel through. 3) Deduce that the moon is a silent place. 4) Construct a string telephone. 5) Understand what makes a bush fire roar. 	
Investigate sounds in nature.	<ol style="list-style-type: none"> 1) Locate places and objects using sound as the only clue. 2) Construct a sound map of the playground. 3) Observe the simple structure of the ear. 4) Visualise a world without sound. 5) Discuss ways in which our hearing can be protected. 	

WHAT MAKES A BUSH FIRE ROAR

You might have to visit the science laboratory at your local high school to do this.

YOU WILL NEED:

- A very big bunsen burner.
- A large cardboard tube.

Your teacher will hold the tube over the flame from the bunsen burner as shown in the diagram.

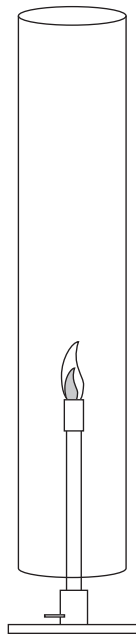

What do you hear? _____

Feel the sides of the tube. What do you feel? _____

The heat from the flame passes up through the tube and makes the air inside the tube vibrate.

VIBRATIONS MAKE SOUND

When a bush fire is burning there is a very large amount of heat energy given off. This heat causes the air to vibrate and makes the roaring sound of the bush fire.

SOUNDS AROUND US

You will need:

- rubber band

This is what you do:

1. Stretch a rubber band around your thumb and forefinger.
2. Pluck it to make a noise.
3. Now hold one end of the rubber band in your teeth and the other end in your finger. Be careful - don't let go!
4. Pluck the rubber band again. Does it sound different?

Write what happened:

When the rubber band is between your teeth, the vibrations of the rubber band pass through your teeth to your jaw bone and the bones of your skull. The sound travels to your inner ear and seems very loud. Your own voice sounds different to you than to other people because most of the sounds travel through your bones rather than through the air.

To Try:

Next time you're in the bath, put one ear under water while tapping a spoon on the side of the bath. Notice how much better the tapping noise travels through water.

STUCK ON YOU

STUCK ON YOU

OUTCOMES	TEACHING STRATEGY	RESOURCES
Investigate the basic properties of magnets.	<ol style="list-style-type: none"> 1) Draw different types of magnets. 2) Locate places where magnets are found. 3) Recognise forces of attraction which exist between magnets and other objects. 4) Examine forces of attraction and repulsion which exist between magnets. 	
Investigate the basic properties of static electricity.	<ol style="list-style-type: none"> 1) Discuss times and places where we are most likely to become zapped by static electricity. 2) Charge a plastic ruler and attract small pieces of paper to it. 3) Understand that lightning is a result of static electricity. 4) Realise that lightning is a major cause of bush fires. 	
Recognise how our knowledge of magnetism makes for useful things.	<ol style="list-style-type: none"> 1) List some uses of magnets. 2) Locate magnets inside of an electric motor and generator. 3) Realise that the electricity we use comes from moving magnetism. 4) Discuss situations where static electricity provides benefit, eg. collecting dust. 	